



Product availability: Non-Stock - Not normally stocked in distribution facility

Price*: 479.00 USD



Main

Range of product	Modicon M241
Product or component type	Logic controller
[Us] rated supply voltage	24 V DC
Discrete input number	14, discrete input 8 fast input IEC 61131-2 Type 1
Discrete output type	Transistor
Discrete output number	10 transistor 4 fast output
Discrete output voltage	24 V DC transistor output
Discrete output current	0.5 A transistor output Q0...Q9 0.1 A fast output (PTO mode) Q0...Q3)

Complementary

Discrete I/O number	24
Maximum number of I/O expansion module	7 local 14 remote
Supply voltage limits	20.4...28.8 V
Inrush current	50 A
Power consumption in W	32.6...40.4 W with max number of I/O expansion module)
Discrete input logic	Sink or source
Discrete input voltage	24 V
Discrete input voltage type	DC
Voltage state 1 guaranteed	>= 15 V input
Voltage state 0 guaranteed	<= 5 V input
Discrete input current	5 MA input 10.7 MA fast input
Input impedance	4.7 kOhm input 2.81 kOhm fast input

Response time	50 µs turn-on, I0...I13 input 50 µs turn-off, I0...I13 input <= 2 µs turn-on, I0...I7 fast input <= 2 µs turn-off, I0...I7 fast input <= 34 µs turn-on, Q0...Q9 output <= 250 µs turn-off, Q0...Q9 output <= 2 µs turn-on, Q0...Q3 fast output <= 2 µs turn-off, Q0...Q3 fast output
Configurable filtering time	1 µs fast input 12 ms fast input 0 ms input 1 ms input 4 ms input 12 ms input
Discrete output logic	Positive logic (source)
Output voltage limits	30 V DC
Maximum current per output common	2 A Q0...Q3 fast output 2 A Q4...Q7 output 1 A Q8...Q9 output
Maximum output frequency	20 KHz fast output (PWM mode) 100 KHz fast output (PLS mode) 1 KHz output
Accuracy	+/- 0.1 % 0.02...0.1 kHz fast output +/- 1 % 0.1...1 kHz fast output
Maximum leakage current	5 MA output
Maximum voltage drop	<1 V
Maximum tungsten load	<2.4 W
Protection type	Short-circuit protection Short-circuit and overload protection with automatic reset Reverse polarity protection fast output
Reset time	10 Ms automatic reset output 12 S automatic reset fast output
Memory capacity	8 MB program 64 MB system memory RAM
Data backed up	128 MB built-in flash memory backup of user programs
Data storage equipment	<= 16 GB SD card optional)
Battery type	BR2032 lithium non-rechargeable 4 year(s)
Backup time	2 years 77 °F (25 °C)
Execution time for 1 KInstruction	0.3 Ms event and periodic task 0.7 Ms other instruction
Application structure	8 external event tasks 8 event tasks 3 cyclic master tasks + 1 freewheeling task 4 cyclic master tasks
Realtime clock	With
Clock drift	<= 60 s/month 77 °F (25 °C)
Positioning functions	PTO 4 100 kHz) PTO 4 transistor output 1 kHz)
Counting input number	4 fast input (HSC mode) 200 kHz 14 standard input 1 kHz
Control signal type	A/B 100 kHz fast input (HSC mode) Pulse/Direction 200 kHz fast input (HSC mode) Single phase 200 kHz fast input (HSC mode)
Integrated connection type	Non isolated serial link serial 1 RJ45 RS232/RS485 Non isolated serial link serial 2 removable screw terminal block RS485 USB port mini B USB 2.0 Ethernet RJ45
Supply	Serial 1)serial link supply 5 V, <200 mA
Transmission rate	1.2...115.2 kbit/s (115.2 kbit/s by default) 49.21 ft (15 m) RS485 1.2...115.2 kbit/s (115.2 kbit/s by default) 9.84 ft (3 m) RS232 480 Mbit/s 9.84 ft (3 m) USB 10/100 Mbit/s Ethernet
Communication port protocol	Non isolated serial link Modbus master/slave

Port Ethernet	10BASE-T/100BASE-TX - 1 copper cable
Communication service	<p>FDR</p> <p>DHCP server via TM4 Ethernet switch network module</p> <p>DHCP client embedded Ethernet port</p> <p>SMS notifications</p> <p>Updating firmware</p> <p>SNMP client/server</p> <p>Programming</p> <p>NGVL</p> <p>Monitoring</p> <p>IEC VAR ACCESS</p> <p>FTP client/server</p> <p>Downloading</p> <p>SQL client</p> <p>Modbus TCP client I/O scanner</p> <p>Ethernet/IP originator I/O scanner embedded Ethernet port</p> <p>Ethernet/IP target, Modbus TCP server and Modbus TCP slave</p> <p>Send and receive email from the controller based on TCP/UDP library</p> <p>Web server (WebVisu & XWeb system)</p> <p>OPC UA server</p> <p>DNS client</p>
Local signalling	<p>For PWR 1 LED (green)</p> <p>For RUN 1 LED (green)</p> <p>For module error (ERR) 1 LED (red)</p> <p>For I/O error (I/O) 1 LED (red)</p> <p>For SD card access (SD) 1 LED (green)</p> <p>For BAT 1 LED (red)</p> <p>For SL1 1 LED (green)</p> <p>For SL2 1 LED (green)</p> <p>For bus fault on TM4 (TM4) 1 LED (red)</p> <p>For I/O state 1 LED per channel (green)</p> <p>for Ethernet port activity 1 LED (green)</p>
Electrical connection	<p>Removable screw terminal block for inputs and outputs pitch 5.08 mm)</p> <p>removable screw terminal block for connecting the 24 V DC power supply pitch 5.08 mm)</p>
Maximum cable distance between devices	<p>Unshielded cable <164.04 ft (50 m) input</p> <p>Shielded cable <32.81 ft (10 m) fast input</p> <p>Unshielded cable <164.04 ft (50 m) output</p> <p>Shielded cable <9.84 ft (3 m) fast output</p>
Insulation	<p>Between supply and internal logic 500 V AC</p> <p>Non-insulated between supply and ground</p> <p>Between input and internal logic 500 V AC</p> <p>Non-insulated between inputs</p> <p>Between fast input and internal logic 500 V AC</p> <p>Between output and internal logic 500 V AC</p> <p>Non-insulated between outputs</p> <p>Between fast output and internal logic 500 V AC</p> <p>Between output groups 500 V AC</p>
Marking	CE
Surge withstand	<p>1 KV power lines (DC) common mode EN/IEC 61000-4-5</p> <p>1 KV shielded cable common mode EN/IEC 61000-4-5</p> <p>0.5 KV power lines (DC) differential mode EN/IEC 61000-4-5</p> <p>1 KV relay output differential mode EN/IEC 61000-4-5</p> <p>1 KV input common mode EN/IEC 61000-4-5</p> <p>1 KV transistor output common mode EN/IEC 61000-4-5</p>
Web services	Web server
Maximum number of connections	<p>8 Modbus server</p> <p>8 SoMachine protocol</p> <p>10 web server</p> <p>4 FTP server</p> <p>16 Ethernet/IP target</p> <p>8 Modbus client</p>
Number of slave	<p>64 Modbus TCP</p> <p>16 EtherNet/IP</p>
Cycle time	<p>10 Ms 16 EtherNet/IP</p> <p>64 Ms 64 Modbus TCP</p>
Mounting support	<p>Top hat type TH35-15 rail IEC 60715</p> <p>Top hat type TH35-7.5 rail IEC 60715</p> <p>plate or panel with fixing kit</p>
Height	3.54 In (90 mm)

Depth	3.74 In (95 mm)
Width	5.91 In (150 mm)
Net weight	1.17 Lb(US) (0.53 kg)

Environment

Standards	ANSI/ISA 12-12-01 CSA C22.2 No 142 CSA C22.2 No 213 EN/IEC 61131-2:2007 Marine specification (LR, ABS, DNV, GL) UL 1604 UL 508
Product certifications	CULus IACS E10 RCM CSA
Resistance to electrostatic discharge	8 KV in air EN/IEC 61000-4-2 4 KV on contact EN/IEC 61000-4-2
Resistance to electromagnetic fields	9.14 V/M (10 V/m) 80 MHz...1 GHz EN/IEC 61000-4-3 2.74 V/M (3 V/m) 1.4 GHz...2 GHz EN/IEC 61000-4-3 0.91 V/M (1 V/m) 2 GHz...3 GHz EN/IEC 61000-4-3
Resistance to fast transients	2 KV EN/IEC 61000-4-4 power lines) 1 KV EN/IEC 61000-4-4 Ethernet line) 1 KV EN/IEC 61000-4-4 serial link) 1 KV EN/IEC 61000-4-4 input) 1 KV EN/IEC 61000-4-4 transistor output)
Resistance to conducted disturbances	10 V 0.15...80 MHz EN/IEC 61000-4-6 3 V 0.1...80 MHz Marine specification (LR, ABS, DNV, GL) 10 V spot frequency (2, 3, 4, 6.2, 8.2, 12.6, 16.5, 18.8, 22, 25 MHz) Marine specification (LR, ABS, DNV, GL)
Electromagnetic emission	Conducted emissions 120...69 dB μ V/m QP power lines)10...150 kHz EN/IEC 55011 Conducted emissions 63 dB μ V/m QP power lines)1.5...30 MHz EN/IEC 55011 Radiated emissions 40 dB μ V/m QP class A30...230 MHz EN/IEC 55011 Conducted emissions 79...63 dB μ V/m QP power lines)150...1500 kHz EN/IEC 55011 Radiated emissions 47 dB μ V/m QP class A230...1000 MHz EN/IEC 55011
Immunity to microbreaks	10 Ms
Ambient air temperature for operation	14...122 °F (-10...50 °C) vertical installation) 14...131 °F (-10...55 °C) horizontal installation)
Ambient air temperature for storage	-13...158 °F (-25...70 °C)
Relative humidity	10...95 %, without condensation in operation) 10...95 %, without condensation in storage)
IP degree of protection	IP20 with protective cover in place
Pollution degree	2
Operating altitude	0...6561.68 ft (0...2000 m)
Storage altitude	0.00...9842.52 Ft (0...3000 m)
Vibration resistance	3.5 mm 5...8.4 Hz symmetrical rail 3 gn 8.4...150 Hz symmetrical rail 3.5 mm 5...8.4 Hz panel mounting 3 gn 8.4...150 Hz panel mounting
Shock resistance	15 gn 11 ms

Ordering and shipping details

Category	22533 - M2XX PLC & ACCESSORIES
Discount Schedule	MSX
GTIN	03606480611193
Nbr. of units in pkg.	1
Package weight(Lbs)	1 Lb(US) (0.45 kg)
Returnability	Yes
Country of origin	ID

Packing Units

Unit Type of Package 1	PCE
Package 1 Height	4.46 In (11.33 cm)
Package 1 width	5.16 In (13.095 cm)
Package 1 Length	7.36 In (18.689 cm)

Offer Sustainability

Sustainable offer status	Green Premium product
California proposition 65	WARNING: This product can expose you to chemicals including: Lead and lead compounds, which is known to the State of California to cause cancer and birth defects or other reproductive harm. For more information go to www.P65Warnings.ca.gov
REACH Regulation	REACH Declaration
EU RoHS Directive	Pro-active compliance (Product out of EU RoHS legal scope) EU RoHS Declaration
Mercury free	Yes
RoHS exemption information	Yes
China RoHS Regulation	China RoHS Declaration
Environmental Disclosure	Product Environmental Profile
Circularity Profile	End Of Life Information
WEEE	The product must be disposed on European Union markets following specific waste collection and never end up in rubbish bins.
PVC free	Yes

Dimensions

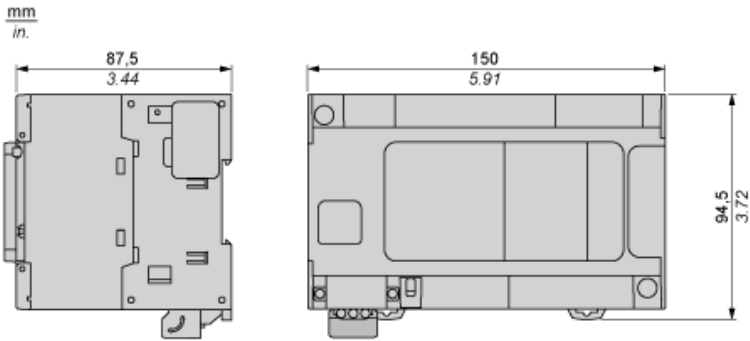

Clearance

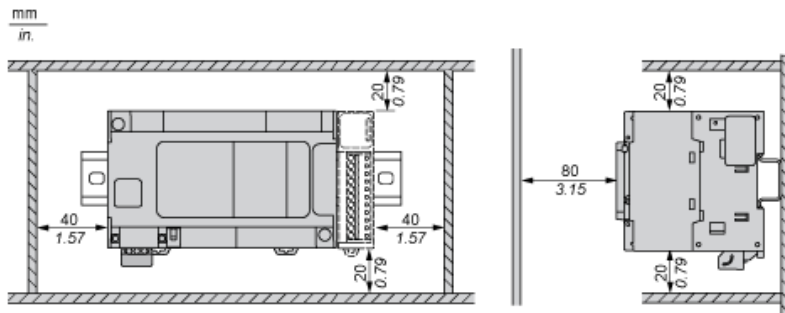

Mounting Position

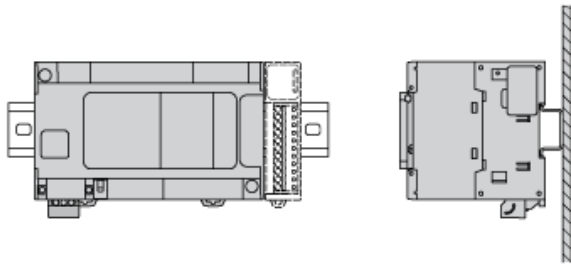

Acceptable Mounting

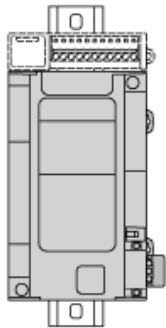

NOTE: Expansion modules must be mounted above the logic controller.

Incorrect Mounting

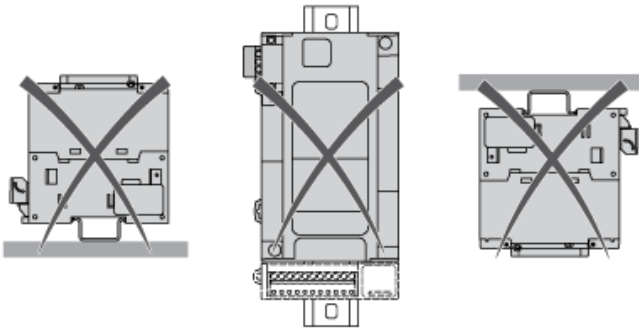

Direct Mounting On a Panel Surface

Mounting Hole Layout

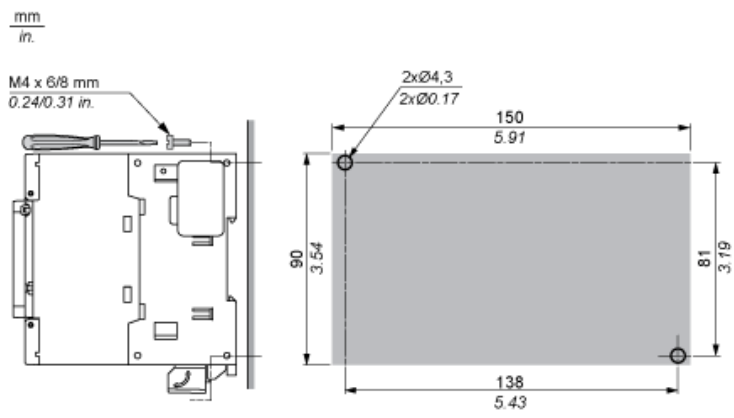

Digital Inputs

Wiring Diagram

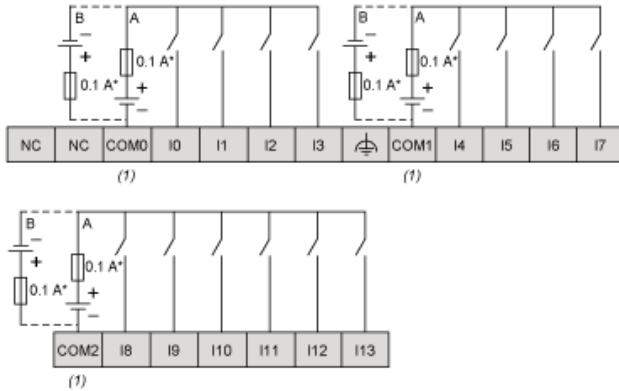

- (*) : Type T fuse
- (1) : The COM0, COM1 and COM2 terminals are not connected internally
- (A) : Sink wiring (positive logic)
- (B) : Source wiring (negative logic)

Fast Input Wiring (I0...I7)

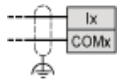

Fast Transistor Outputs

Wiring Diagram

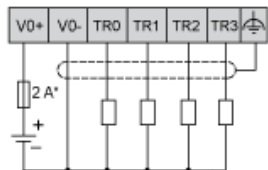

- (*) : 2 A fast-blow fuse

Transistor Outputs

Wiring Diagram

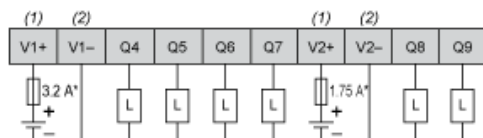

- (*) : Type T fuse
- (1) : The V1+ and V2+ terminals are not connected internally.
- (2) : The V1- and V2- terminals are not connected internally.

USB Mini-B Connection

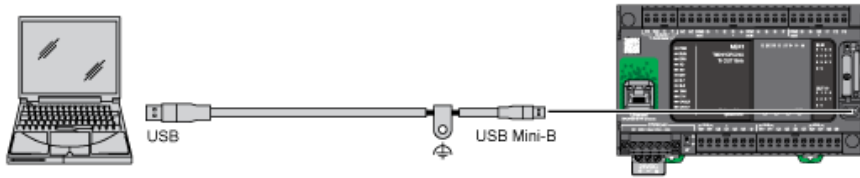

Ethernet Connection to a PC

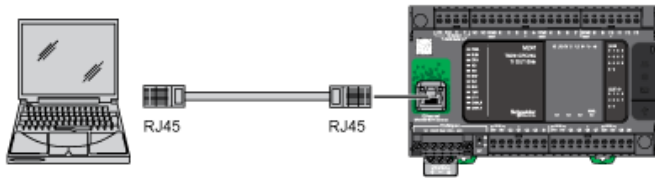

Product Life Status : **Commercialised**